

DS312X OPTICAL FLAP TURNSTILE
SINGLE / BI-DIRECTION



- Optical flap turnstile is to control pedestrian entry or exit in restricted areas, usually used in high pedestrian traffic flow in both directions.
- The body is made of brushed stainless steel which is robust, rigid, anti-rust, waterproof and durable.
- It is ideal for both indoor and outdoor settings.
- It has standard relay signal, which can be integrated with any kind of third-party access control system (e.g.: RFID, Fingerprint and Biometric reader device).
- It has sufficient space, which can be mounted with any type of external device(e.g.: Display, Counter, Reader, Push button, Card collector, Coin insert, Barcode/QR reader, Wheel).
- In case of emergency, the flap arms will open automatically to allow free passage when power off.
- It is suitable for areas with high pedestrian traffic (e.g.: Hotel, Building, Dormitory, Station, Airport, Park).

Features

- ✓ Long-life performance, high operation dependability and fast response.
- ✓ The whole system runs smoothly, low noise, no mechanical impact.
- ✓ Single directional or Bi-directional is selectable.
- ✓ Automatic reset function: flap arms will lock automatically within 5s (can be setting) if passenger delay to entry.
- ✓ When power is off, flap arms will open automatically, which is complying with fire safety requirements.
- ✓ LED indicator (red × means no entry; green → means entry).
- ✓ Easy to install and maintain.
- ✓ 3-year warranty support.
- ✓ Infrared sensor alarm function, in case of illegal intrusion and reverse intrusion.
- ✓ Anti-intrusion function, the turnstile is locked automatically until valid opening signal input.
- ✓ Anti-reverse function, the turnstile alarms if someone wants to entry in the reverse direction.
- ✓ Anti-trailing function, the turnstile alarm if someone wants to burst in without permission.

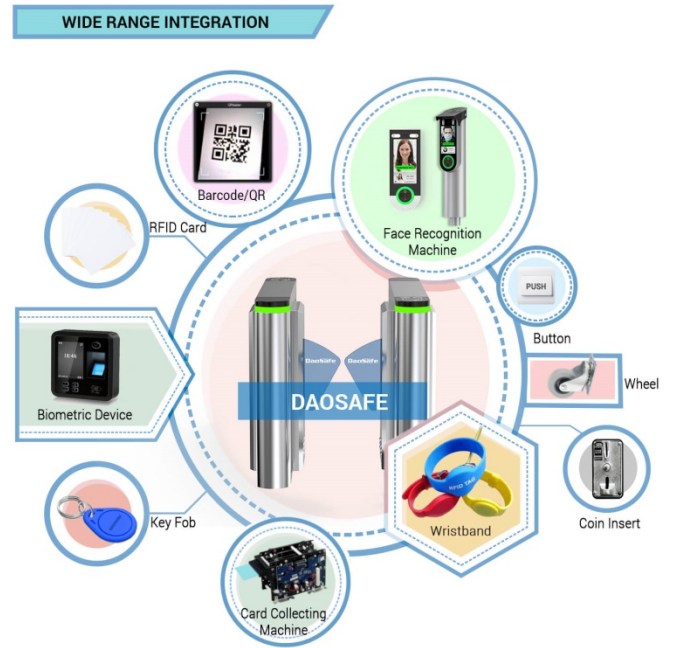

Specifications

Model No.	DS312X
Framework Material	304 Stainless Steel+ Plexiglas Arm+ Tempered Glass
Brand	Daosafe
Arm material	Plexiglas-transparency
Dimension	1200 * 300 * 1000mm
Net Weight	80kg/pcs,100kg/pcs
Passage Width	550mm (One passage)
Passing Direction	Single directional / Bi-directional
MCBF	5 million
Power Supply	AC220V/110V, 50/60Hz
Operation Voltage	24V DC
Power Consumption	40W
Operation Temperature	-15 °C - 60 °C
Operation Humidity	0 ~ 95% (No freeze)
Working Environment	Indoor / Outdoor
Flow Rate	40-45 people per minute
LED Indicator	Yes
Infrared Sensor	3 pairs(standard)
Emergency	Automatic arm open when power off
Communication	Dry contact, Relay signal, RS485

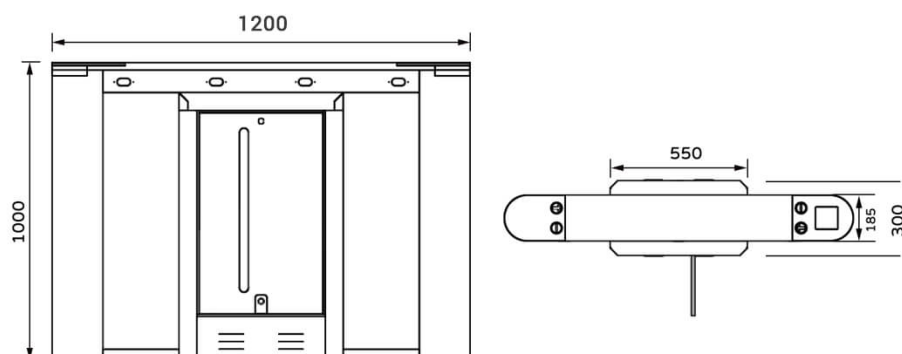

System Integration Figure

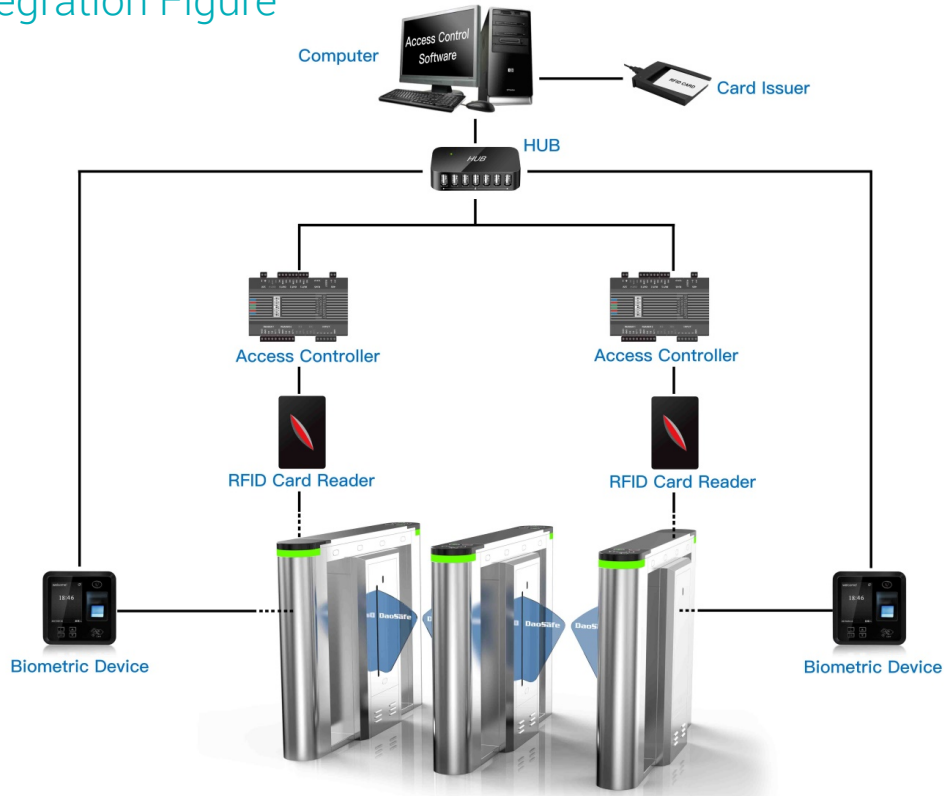

Optical Flap Turnstile DS312X

Range of Applications

